

12) Surrounding Area Conditions:

- a) The enclosure is manufactured from ABS/Polycarbonate.
The capillary sensing tube and bulb are copper.
The performance of these materials should be considered with respect to contact with aggressive substances with which the unit may come into contact.
- b) Dust or other material should not be allowed to accumulate on or cover the unit. The surface may be cleaned with a damp cloth.
- c) The thermostat unit is intended for use under normal industrial conditions and should not be installed in an area where extreme vibration may occur.

13) The installation of this product must be carried out by suitably trained and qualified personnel



MOUNTING

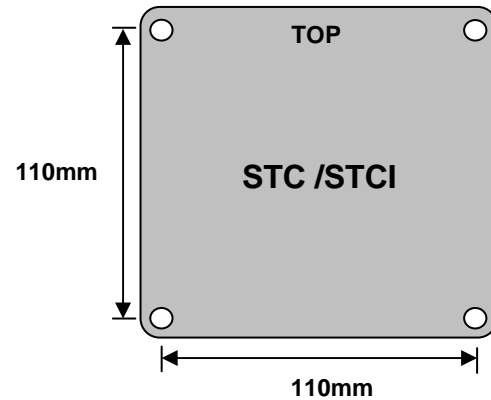

OPERATING INSTRUCTIONS

Type STC & STCI Thermostat

ESH TRACE HEATING LTD
UNIT 10, HORTONWOOD 33,
TELFORD, SHROPSHIRE. TF1 7EX
Tel (01952) 604033 Fax (01952) 608122
Email: enquiries@eshltd.com Web Site www.eshltd.com

INSTALLATION INSTRUCTIONS

- 1) Type STC/I Thermostats are electro-mechanical thermostat units suitable for use as temperature control unit for electric surface heating systems in non-hazardous areas.
 - 2) Units may be used as either an air sensing or pipe sensing thermostat. Removal of the bulb from the housing tube converts the unit into pipe sensing.
 - 3) Maximum Current Rating : 16 amp
 - 4) Maximum Voltage : 240V
 - 5) Ingress Protection : 66
 - 6) Ranges :
- Thermostats Available:
- | | |
|------------|--|
| Type STC: | Controlling switching for a measured air and pipe temperature range of 0°C to +90°C. |
| Type STCI: | Controlling switching for a measured air and pipe temperature range of 0°C to +90°C. |
- 7) Enclosure:

STC:	ABS
STCI:	ABS with Polycarbonate Lid.
 - 8) Installation:
 - a) The thermostat unit should be mounted securely to a suitable flat surface or on a mounting plate securely fixed to the pipework.
 - d) Cover fixing screws should be tightened to ensure the lid is correctly fitted.
 - f) Flexing and bending of the sensor capillary tube should be kept to a minimum.
 - g) The sensing bulb when using in a pipe sensing role should be securely fixed in good contact with the surface of the pipe or vessel being controlled. This may be done using an adhesive tape or tension banding suitable for the maximum operating surface temperature of the pipe or vessel.
 - h) Surfaces should be clean and dry when using adhesive tape.
 - 9) Thermostat Setting:
 - a. The thermostat should be set to the required operating temperature by turning the control knob until the required temperature is opposite the marker arrow.
 - b. For frost protection set the temperature at 3°C – 5°C.
 - c. For temperature maintaining set to the required temperature.

10) Electrical:

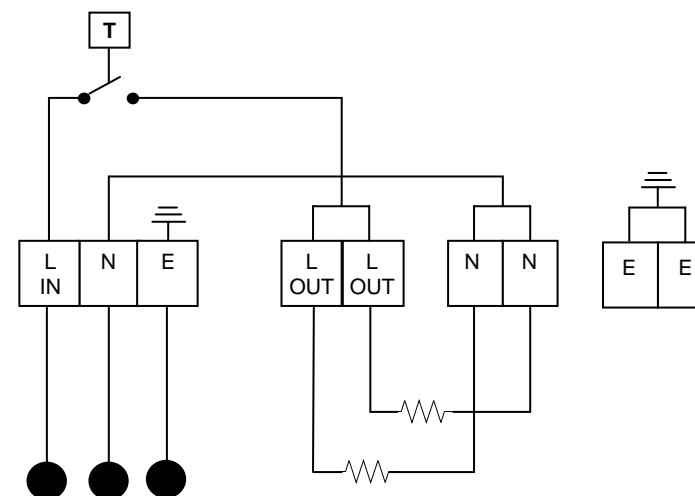

- a. Cable entry to the enclosure should be via an appropriate rated gland.
- b. Maximum conductor size shall be 2.5mm².
- c. Connect the incoming supply to Supply L (live) and N (neutral) E (earth).
- d. All conductors must be fully tightened down within the equipment terminals. It is important that the correct size of screwdriver is used as an oversized screwdriver may damage the terminal insulation.

11) Maintenance:

- a. Periodic inspection of the unit is necessary.
- b. Particular attention should be paid to: tightening of terminal screws, cover fixing screws and earthing assemblies. If any parts are lost or require replacement contact ESH Trace Heating Ltd for the appropriate replacement part. Only approved replacement parts should be used to avoid invalid certification.
- c. The thermostat settings and operation should be checked annually prior to commencement of winter for frost protection application.
- d. For process control temperature it is recommended that maintenance checks should be carried out at least in six month intervals.
- e. There are no maintainable parts within the thermostat unit.
- f. **CAUTION:** Removal of the cover and/or operation of the control knob should only be carried out by correctly trained personnel.